



Digital Camera Step-Up Slave DC-DC Controller

MAX1801

General Description

The MAX1801 step-up slave DC-DC controller is used with either the MAX1800 (step-up) or the MAX1802 (step-down) master DC-DC converter to provide a complete power-supply solution for digital still and digital video cameras. By using the master converter's reference voltage and oscillator, the size and the cost of the slave controller are reduced and all converters are guaranteed to switch at the same frequency.

The MAX1801 drives an external N-channel MOSFET and can be used in step-up, single-ended primary inductance converter (SEPIC), and flyback topologies. If extra supplies are required for a new design, slave controllers can be added to an existing master circuit with minimal redesign, saving both cost and time. The MAX1801 features a built-in soft-start, short-circuit protection, and an adjustable duty-cycle limit.

The MAX1801 is available in a space-saving 8-pin SOT23 package. Separate evaluation kits combining the MAX1800/MAX1801 (MAX1800EVKIT) and MAX1802/MAX1801 (MAX1802EVKIT) are available to expedite designs.

Applications

- | | |
|-----------------------|-------------------------|
| Digital Still Cameras | Internet Access Tablets |
| Digital Video Cameras | PDA's |
| Portable DVD Players | Hand-Held Devices |

Features

- ◆ Provides Simple Expandability for the MAX1800 and MAX1802 Master Converters
- ◆ Operates in Step-Up, SEPIC, and Flyback Topologies
- ◆ 100kHz to 1MHz Adjustable Operating Frequency
- ◆ Duty-Cycle Limit Adjustable from 40% to 90%
- ◆ Soft-Start
- ◆ Short-Circuit Protection
- ◆ 0.01µA Supply Current in Shutdown Mode
- ◆ Tiny 8-Pin SOT23 Package

Ordering Information

PART	TEMP. RANGE	PIN-PACKAGE
MAX1801EKA-T	-40°C to +85°C	8 SOT23-8

Pin Configuration appears at end of data sheet.

Typical Operating Circuit

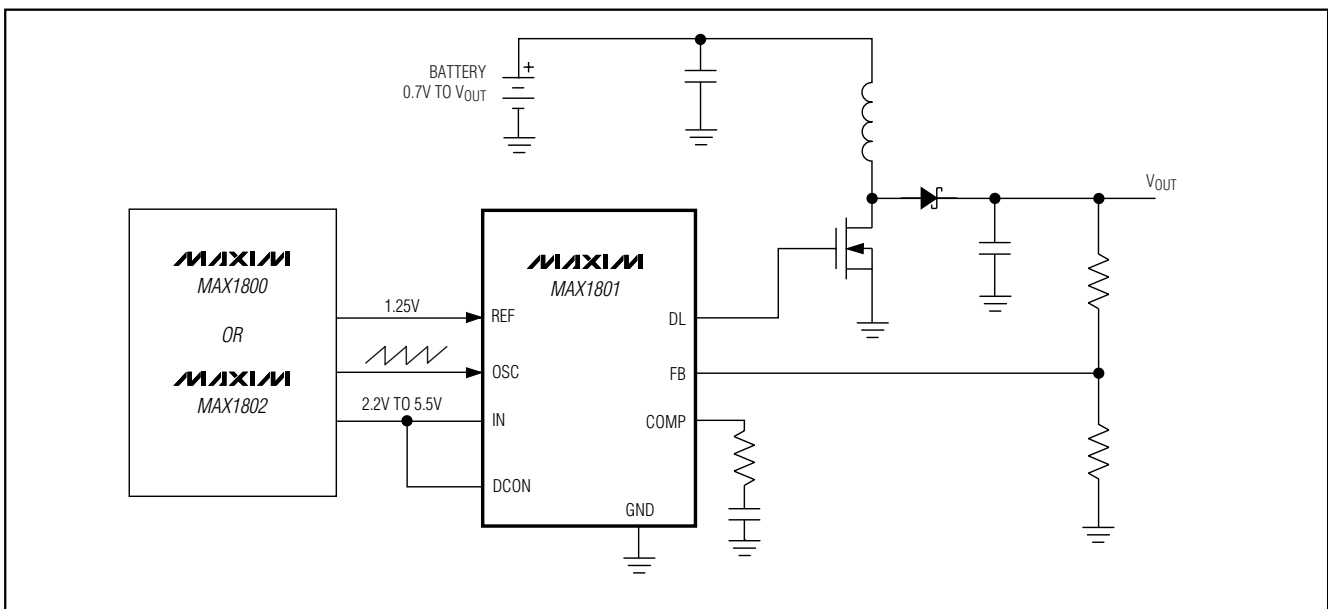

Digital Camera Step-Up Slave DC-DC Controller

ABSOLUTE MAXIMUM RATINGS

IN, DCON, REF, OSC, FB to GND	-0.3V to +6.0V	Operating Temperature Range	-40°C to +85°C
DL, COMP to GND	-0.3V to (V _{IN} + 0.3V)	Junction Temperature	+150°C
Continuous Power Dissipation (T _A = +70°C)		Storage Temperature Range	-65°C to +150°C
8-Pin SOT23 (derate 6mW/°C above +70°C)	480mW	Lead Temperature (soldering, 10s)	+300°C

Stresses beyond those listed under "Absolute Maximum Ratings" may cause permanent damage to the device. These are stress ratings only, and functional operation of the device at these or any other conditions beyond those indicated in the operational sections of the specifications is not implied. Exposure to absolute maximum rating conditions for extended periods may affect device reliability.

ELECTRICAL CHARACTERISTICS

(Circuit of Figure 1, V_{IN} = +3.3V, V_{DCON} = +1.25V, V_{REF} = +1.25V, T_A = 0°C to +85°C, unless otherwise noted. Typical values are at T_A = +25°C.) (Note 1)

PARAMETER	CONDITIONS	MIN	TYP	MAX	UNITS
GENERAL					
V _{IN} Supply Voltage Operating Range		2.7		5.5	V
V _{IN} Undervoltage Lockout Threshold	V _{IN} rising	2.2	2.35	2.5	V
REF Input Range		1.19	1.25	1.31	V
REF Undervoltage Lockout Threshold	V _{REF} rising	0.9	1.0	1.1	V
Shutdown Supply Current	V _{IN} = 5.5V, V _{DCON} = 0, V _{REF} = 0		0.01	1	μA
Sleep-Mode Supply Current	V _{IN} = 3.3V, V _{DCON} = 0, V _{REF} = 1.25V		5	10	μA
Quiescent Supply Current	V _{OSC} = 0, V _{FB} = 0		124	300	μA
OSCILLATOR INPUT					
OSC Input Leakage Current	V _{OSC} = 1.5V		0.04	1	μA
Oscillator Frequency Range		100		1000	kHz
OSC Clock Low Trip Level		0.20	0.25	0.30	V
OSC Clock High Trip Level		1.00	1.05	1.10	V
	V _{DCON} = 0.625V	0.575	0.625	0.675	
Maximum Duty Cycle Adjustment Range (Note 2)	f _{OSC} = 100kHz	40		90	%
Maximum Duty Cycle (Note 2)	V _{DCON} = 0.625V, f _{OSC} = 100kHz		50		%
Default Maximum Duty Cycle (Note 2)	V _{DCON} = 1.25V, f _{OSC} = 100kHz		84		%
INPUTS/OUTPUTS					
DCON Input Leakage Current	V _{DCON} = 5.5V		9	100	nA
DCON Input Sleep-Mode Threshold	I _{IN} ≤ 10μA	0.35	0.4	0.45	V
REF Input Current	V _{DCON} = 0		0.5	1.1	μA
	V _{DCON} = V _{REF}		3.3	10	
	V _{DCON} = V _{REF} , during soft-start		13	30	
ERROR AMPLIFIER					
FB Regulation Voltage		1.238	1.250	1.263	V
FB to COMP Transconductance	-5μA < I _{COMP} < 5μA	70	100	160	μS
FB to COMP Maximum Voltage Gain			2000		V/V
FB Input Leakage Current	V _{FB} = 1.35V		30	100	nA

Digital Camera Step-Up Slave DC-DC Controller

MAX1801

ELECTRICAL CHARACTERISTICS (continued)

(Circuit of Figure 1, $V_{IN} = +3.3V$, $V_{DCON} = +1.25V$, $V_{REF} = +1.25V$, $T_A = 0^{\circ}C$ to $+85^{\circ}C$, unless otherwise noted. Typical values are at $T_A = +25^{\circ}C$.) (Note 1)

PARAMETER	CONDITIONS	MIN	TYP	MAX	UNITS
DRIVER					
DL Driver Resistance			2.5	5	Ω
DL Drive Current			0.5		A
SOFT-START					
Soft-Start Interval			1024		OSC cycles
SHORT-CIRCUIT PROTECTION					
Fault Interval			1024		OSC cycles

ELECTRICAL CHARACTERISTICS

(Circuit of Figure 1, $V_{IN} = +3.3V$, $V_{DCON} = +1.25V$, $V_{REF} = +1.25V$, $T_A = -40^{\circ}C$ to $+85^{\circ}C$, unless otherwise noted.) (Note 1)

PARAMETER	CONDITIONS	MIN	TYP	MAX	UNITS
GENERAL					
V_{IN} Supply Voltage Operating Range		2.7		5.5	V
V_{IN} Undervoltage Lockout Threshold	V_{IN} rising	2.15		2.55	V
REF Input Range		1.19		1.31	V
REF Undervoltage Lockout Threshold	V_{REF} rising	0.85		1.15	V
Shutdown Supply Current	$V_{IN} = 5.5V$, $V_{DCON} = 0$, $V_{REF} = 0$			1	μA
Sleep-Mode Supply Current	$V_{IN} = 3.3V$, $V_{DCON} = 0$, $V_{REF} = 1.25V$			10	μA
Quiescent Supply Current	$V_{OSC} = 0$, $V_{FB} = 0$			300	μA
OSCILLATOR INPUT					
OSC Input Leakage Current	$V_{OSC} = 1.5V$			1	μA
Oscillator Frequency Range		100		1000	kHz
OSC Clock Low Trip Level		0.20		0.30	V
OSC Clock High Trip Level		1.00		1.10	V
	$V_{DCON} = 0.625V$	0.575		0.675	
Maximum Duty Cycle Adjustment Range (Note 2)	$f_{OSC} = 100kHz$	40		90	%
INPUTS/OUTPUTS					
DCON Input Leakage Current	$V_{DCON} = 5.5V$			100	nA
DCON Input Sleep-Mode Threshold	$I_{IN} \leq 10\mu A$	0.35		0.45	V
REF Input Current	$V_{DCON} = 0$			1.1	μA
	$V_{DCON} = V_{REF}$			10	
	$V_{DCON} = V_{REF}$, during soft-start			30	

Digital Camera Step-Up Slave DC-DC Controller

ELECTRICAL CHARACTERISTICS (continued)

(Circuit of Figure 1, $V_{IN} = +3.3V$, $V_{DCON} = +1.25V$, $V_{REF} = +1.25V$, $T_A = -40^{\circ}C$ to $+85^{\circ}C$, unless otherwise noted.) (Note 1)

PARAMETER	CONDITIONS	MIN	TYP	MAX	UNITS
ERROR AMPLIFIER					
FB Regulation Voltage		1.238		1.263	V
FB to COMP Transconductance	$-5\mu A < I_{COMP} < 5\mu A$	70		160	μS
FB Input Leakage Current	$V_{FB} = 1.35V$			100	nA
DRIVER					
DL Driver Resistance				5	Ω

Note 1: All devices are 100% tested at $T_A = +25^{\circ}C$. All limits over the temperature range are guaranteed by design.

Note 2: Oscillator signal is generated by the MAX1800 or MAX1802.

Typical Operating Characteristics

(Circuit of Figure 1, $T_A = +25^{\circ}C$, unless otherwise noted.)

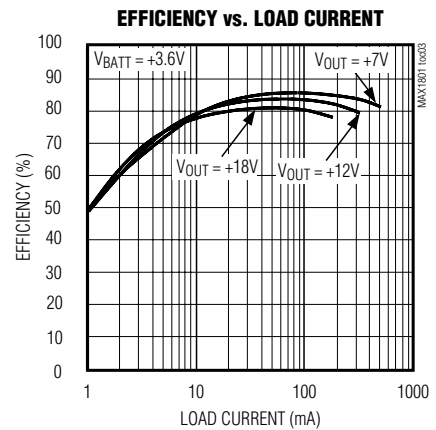
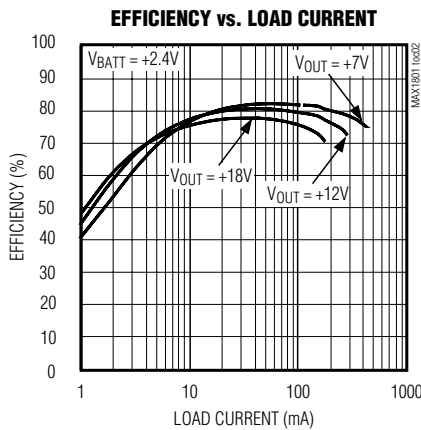
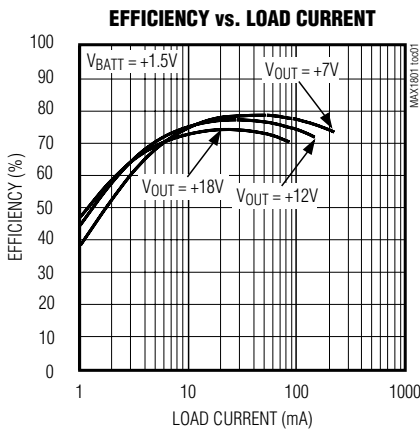

Digital Camera Step-Up Slave DC-DC Controller

MAX1801

Typical Operating Characteristics (continued)

(Circuit of Figure 1, $T_A = +25^\circ\text{C}$, unless otherwise noted.)

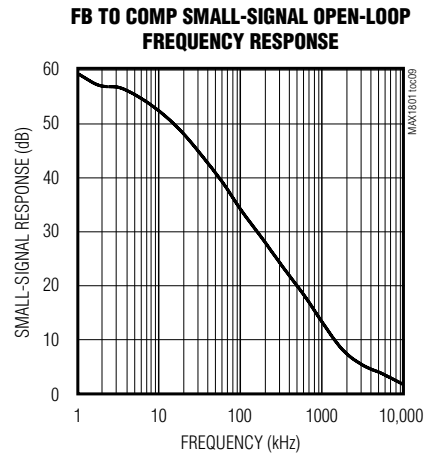
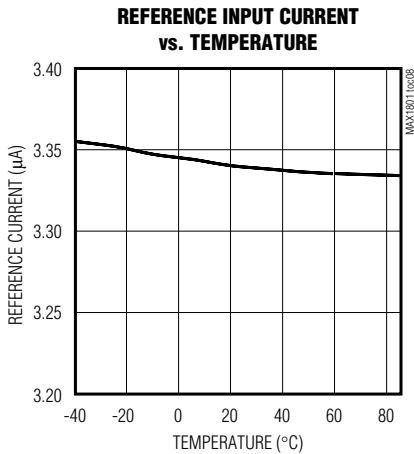
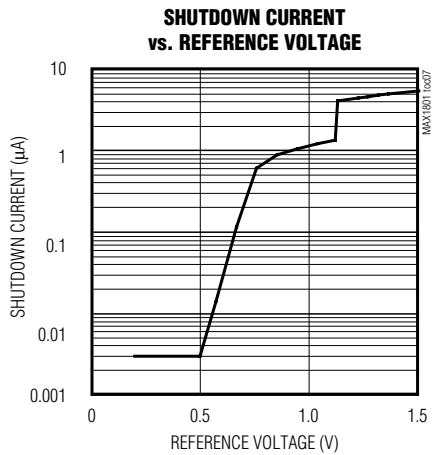
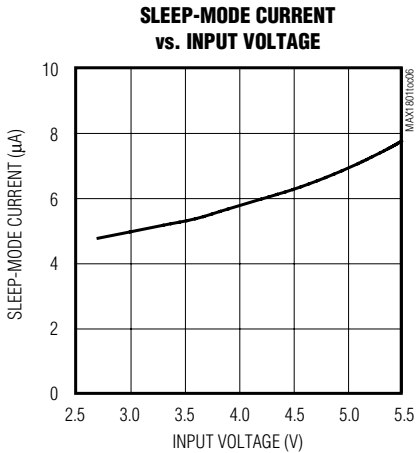
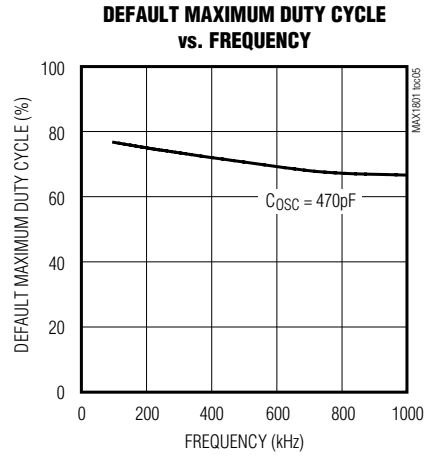
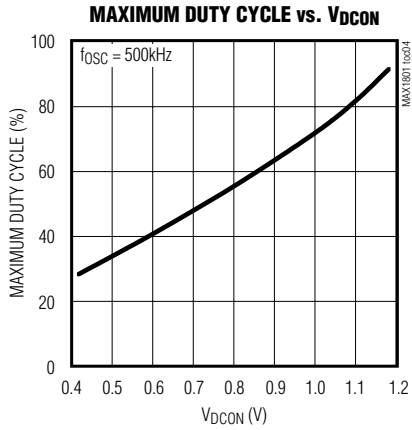

Digital Camera Step-Up Slave DC-DC Controller

Typical Operating Characteristics (continued)

(Circuit of Figure 1, $T_A = +25^\circ\text{C}$, unless otherwise noted.)

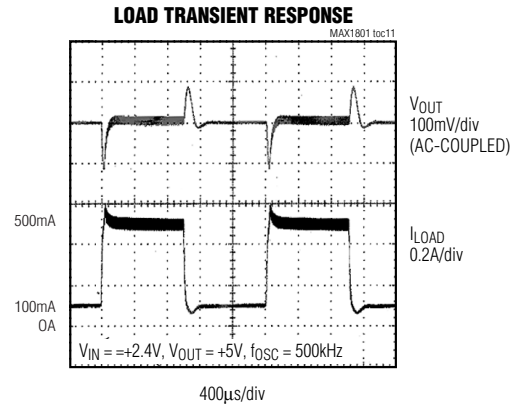
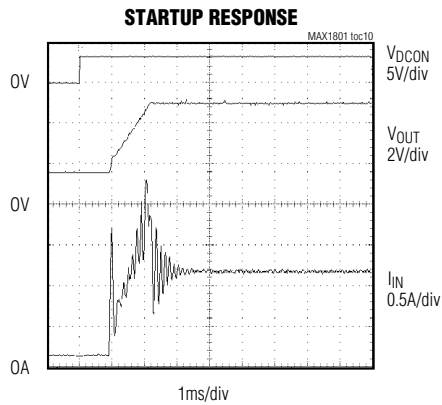

Pin Description

PIN	NAME	FUNCTION
1	OSC	Oscillator Input. Connect OSC to OSC of the MAX1800 or MAX1802. The oscillator frequency must be between 100kHz and 1MHz.
2	GND	Ground
3	REF	1.25V Reference Input. Connect REF to REF of the MAX1800 or MAX1802. REF must be above 1V for the controller to turn on. Bypass REF to GND with a 0.1 μF or greater capacitor.
4	DCON	Maximum Duty-Cycle Control Input. Connect to REF or IN to set the default maximum duty cycle. Connect a resistive voltage-divider from REF to DCON to set the maximum duty cycle between 40% and 90%. Pull DCON below 0.35V to turn the controller off.
5	COMP	Controller Compensation. Output of transconductance error amplifier. Connect a series resistor and capacitor to GND to compensate the control loop. See <i>Compensation Design</i> .
6	FB	Controller Feedback Input. Connect a feedback resistive voltage-divider from the output to FB to set the output voltage. Regulation voltage is V_{REF} (1.25V).
7	IN	IC Supply Bias Input. Bypass IN to GND with a 0.1 μF or greater ceramic capacitor. Supply range is 2.7V to 5.5V.
8	DL	External MOSFET Gate Drive Output. DL swings between IN and GND with typical 500mA drive current. Connect DL to the gate of the external switching N-channel MOSFET.

Digital Camera Step-Up Slave DC-DC Controller

MAX1801

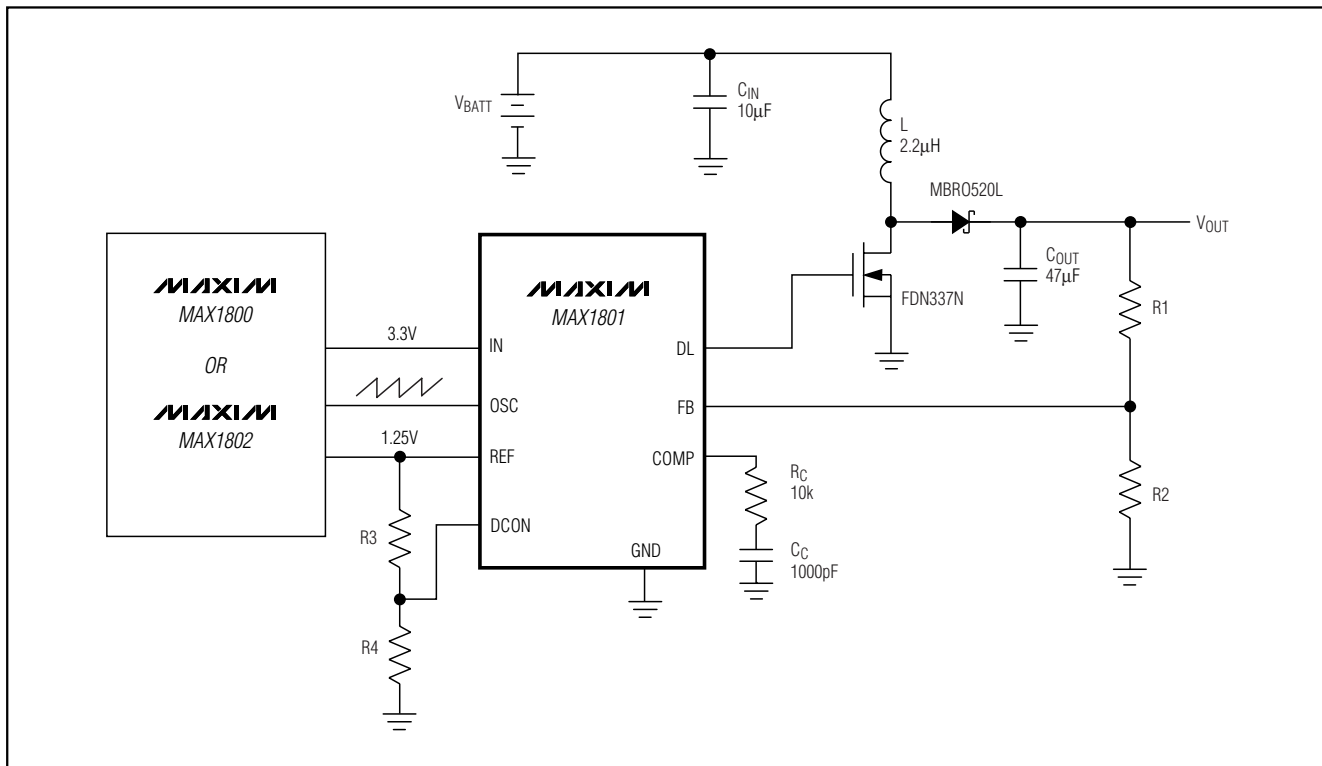

Figure 1. Typical Application Circuit

Detailed Description

Master-Slave Configuration

The MAX1801 is a step-up slave DC-DC controller that obtains its input power, voltage reference, and oscillator signal directly from a MAX1800 or MAX1802 master DC-DC converter (Figure 1). The master-slave configuration reduces system cost by eliminating redundant circuitry and controls the harmonic content of noise by synchronizing converter switching.

Step-Up DC-DC Controller

The MAX1801 controller operates in a low-noise fixed-frequency PWM mode, with output power limited by the external components. The controller regulates the output voltage by modulating the pulse width of the drive signal for an external N-channel MOSFET switch. The user-adjusted switching frequency is constant (100kHz to 1MHz) and set by the master converter.

Figure 2 shows a block diagram of the MAX1801 PWM controller. A sawtooth oscillator signal from the master

converter (at OSC) governs the internal timing. At the beginning of each cycle, DL goes high to turn on the external MOSFET switch. The MOSFET switch turns off when the internally level-shifted sawtooth waveform voltage rises above the voltage at COMP or when the maximum duty cycle is exceeded. The switch remains off until the beginning of the next cycle. An internal transconductance amplifier establishes an integrated error voltage at COMP, increasing the loop gain for improved regulation accuracy and compensation control.

Reference

The MAX1801 requires a 1.25V reference voltage that is obtained from the MAX1800 or the MAX1802. REF typically sinks 0.5µA in shutdown mode, 3µA in active mode, and up to 30µA during startup. If multiple MAX1801 controllers are turned on simultaneously, ensure that the master voltage reference can provide sufficient current, or buffer the reference with an appropriate unity-gain amplifier.

Digital Camera Step-Up Slave DC-DC Controller

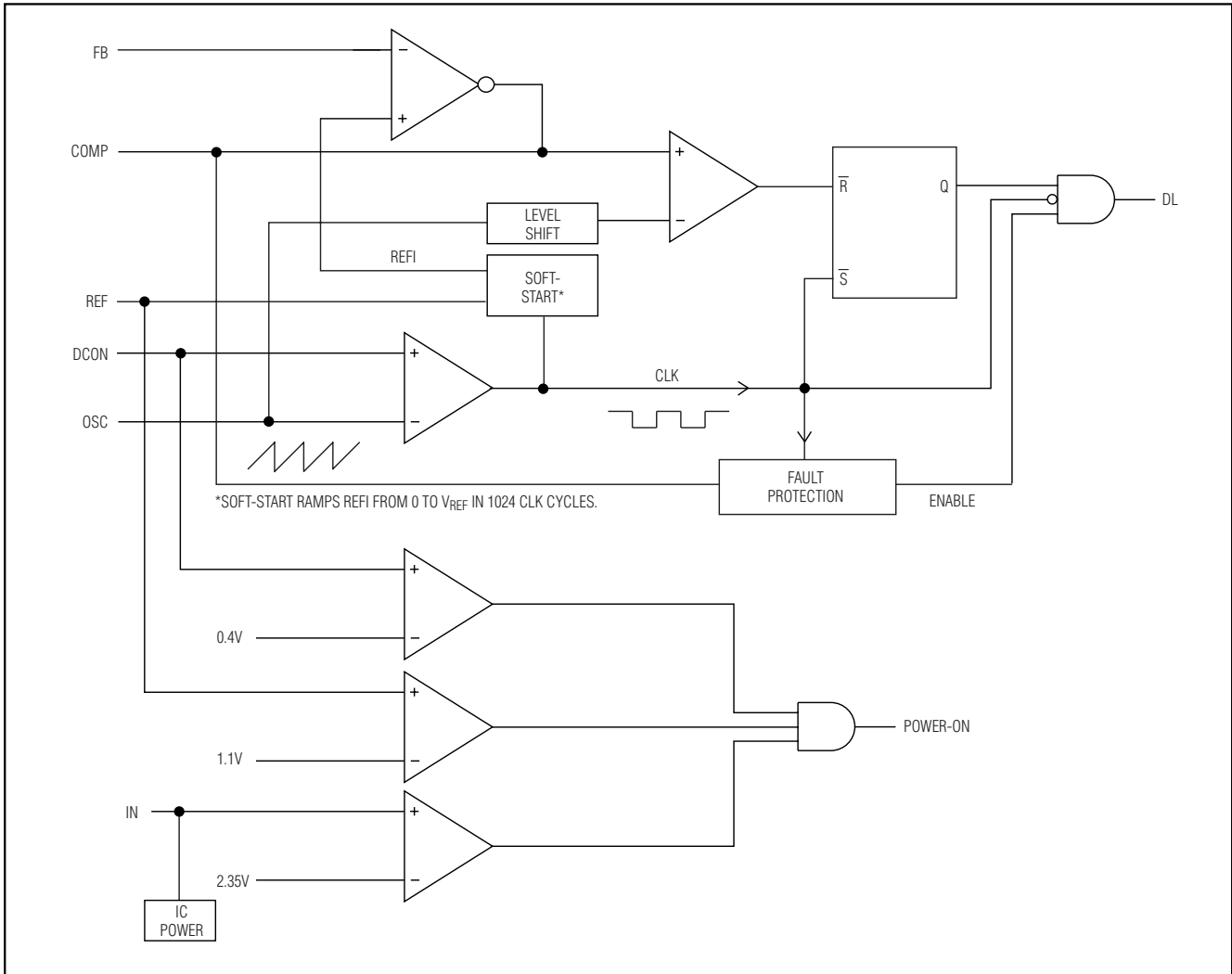

Figure 2. PWM Controller Block Diagram

Oscillator

The MAX1801 requires a 0 to 1.25V sawtooth oscillator signal that is obtained from the MAX1800 or the MAX1802 (at OSC). The 100kHz to 1MHz oscillator signal sets the converter switching frequency, and it is used to control pulse-width modulation and maximum duty cycle.

Maximum Duty Cycle

The MAX1801 uses the master-generated oscillator signal at OSC, the voltage at DCON, and an internal comparator to limit its maximum switching duty cycle (see *Setting the Maximum Duty Cycle*). Limiting the duty cycle can prevent saturation in some magnetic compo-

nents. A low maximum duty cycle can also force the converter to operate in discontinuous current mode, simplifying design stability at the cost of a slight reduction in efficiency.

Soft-Start

The MAX1801 features a soft-start function that limits inrush current and prevents excessive battery loading at startup by ramping the output voltage to the regulation voltage. This is achieved by increasing the internal reference to the transconductance amplifier from 0 to the 1.25V reference voltage over 1024 oscillator cycles when initial power is applied or when the part is taken out of shutdown or sleep mode.

Digital Camera Step-Up Slave DC-DC Controller

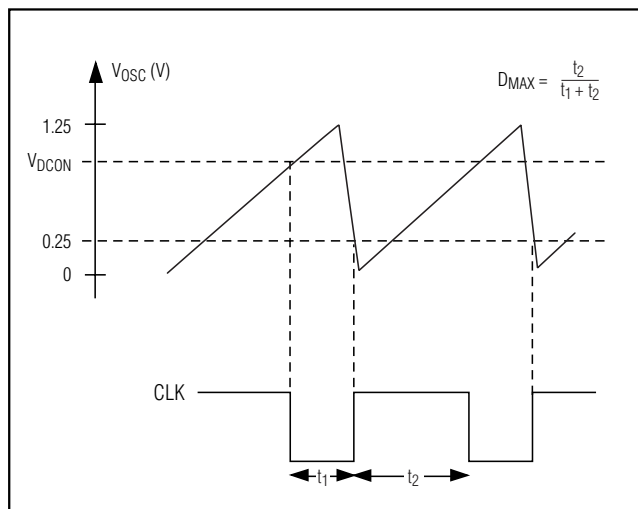

Figure 3. Setting the Maximum Duty Cycle

Shutdown

Set V_{DCON} less than 0.35V to place the MAX1801 in sleep mode, which drops the supply current to 5 μ A. To reduce the supply current to 10nA, place the MAX1801 in shutdown by setting V_{REF} below 0.4V. The MAX1801 enters soft-start when both V_{DCON} and V_{REF} are at normal levels.

Short-Circuit Protection

The MAX1801 has a fault protection feature that prevents damage to transformer-coupled or SEPIC circuits due to an output short circuit. If the output voltage drops out of regulation, the voltage at COMP is clamped at 2.7V. If this condition is maintained for 1024 oscillator clock periods at any time following soft-start, the MAX1801 is disabled to prevent excessive output current. Restart the controller by cycling the voltage at DCON or IN to GND and back to a normal state. For a step-up application, short-circuit current is not limited, due to the DC current path through the inductor and output rectifier to the short circuit. If short-circuit protection is required in a step-up configuration, a protection device such as a fuse must be used to limit short-circuit current.

Design Procedure

The MAX1801 can operate in a number of DC-DC converter configurations, including step-up, SEPIC, and flyback. The following design discussions are limited to the step-up configuration shown in Figure 1; SEPIC and flyback examples are discussed in the *Applications Information* section.

Switching Frequency

The MAX1801 switching frequency is set by the MAX1800 or MAX1802 master converter (refer to the appropriate data sheet for the design procedure). Choose a switching frequency to optimize external component size or efficiency for the particular MAX1801 application. Typically, switching frequencies between 400kHz and 500kHz offer a good balance between component size and efficiency—higher frequencies generally allow smaller components, and lower frequencies give better conversion efficiency.

Setting the Output Voltages

Set the MAX1801 output voltage by connecting a resistive voltage-divider from the output to FB as shown in Figure 1. The FB input bias current is less than 100nA, so choose R2 to be 100k Ω to minimize the effect of input bias current at FB. Choose R1 according to the relation:

$$R1 = R2 \left(\frac{V_{OUT}}{V_{FB}} - 1 \right)$$

where V_{FB} is 1.25V, the regulation set point for the MAX1801.

Setting the Maximum Duty Cycle

The master oscillator signal at OSC and the voltage at DCON are used to generate the internal clock signal (CLK in Figure 2). The internal clock's falling edge occurs when V_{OSC} exceeds V_{DCON} , the voltage at DCON set by a resistive voltage-divider. The internal clock's rising edge occurs when V_{OSC} falls below 0.25V (Figure 3). The maximum duty cycle can be approximated by the equation:

$$D_{MAX} = \frac{R4}{R3 + R4} (1 - f_{OSC} t_{FALL})$$

where f_{OSC} and t_{FALL} are the oscillator frequency (in Hz) and the fall time (typically 100ns), respectively.

At 100kHz, the adjustable maximum duty-cycle range is typically 28% to 92% (see Maximum Duty Cycle vs. V_{DCON} in the *Typical Operating Characteristics*). The maximum duty cycle typically defaults to 78% at 100kHz if V_{DCON} is at or above the voltage at V_{REF} (1.25V), and the controller shuts down if V_{DCON} is less than 0.4V. If a resistive voltage-divider is used at DCON, shut down the MAX1801 by pulling DCON low with an open-drain signal from an external transistor. Drive DCON with appropriate logic levels to turn the MAX1801 on and off if the default duty-cycle limit is used.

Digital Camera Step-Up Slave DC-DC Controller

Inductor Selection

Select the inductor for either continuous or discontinuous current. Continuous conduction generally is the most efficient. Use discontinuous current if the step-up ratio (V_{OUT} / V_{IN}) is greater than $1 / (1 - D_{MAX})$.

Continuous Inductor Current

For most MAX1801 step-up designs, a reasonable inductor value (L_{IDEAL}) can be derived from the following equation, which sets continuous peak-to-peak inductor current at 1/3 the DC inductor current:

$$L_{IDEAL} = \frac{3(V_{IN} - V_{SW})D(1-D)}{I_{OUT} f_{OSC}}$$

where D, the duty cycle, is given by:

$$D \approx 1 - \frac{V_{IN}}{V_{OUT} + V_D}$$

In these equations, V_{SW} is the voltage drop across the N-channel MOSFET switch, and V_D is the forward voltage drop across the rectifier. Given L_{IDEAL} , the consistent peak-to-peak inductor current is $0.333 I_{OUT} / (1 - D)$. The maximum inductor current is $1.167 I_{OUT} / (1 - D)$.

Inductance values smaller than L_{IDEAL} can be used; however, the maximum inductor current will rise as L is reduced, and a larger output capacitance will be required to maintain output ripple.

The inductor current will become discontinuous if I_{OUT} decreases by more than a factor of six from the value used to determine L_{IDEAL} .

Discontinuous Inductor Current

In the discontinuous mode of operation, the MAX1801 controller regulates the output voltage by adjusting the duty cycle to allow adequate power transfer to the load. To ensure regulation under worst-case load conditions (maximum I_{OUT}), choose:

$$L \leq \frac{V_{OUT} D_{MAX}}{2 I_{OUT} f_{OSC}}$$

The peak inductor current is $V_{IN} D_{MAX} / (L f_{OSC})$.

The inductor's saturation current rating should meet or exceed the calculated peak inductor current.

Input and Output Filter Capacitors

The input capacitor (C_{IN}) in step-up designs reduces the current peaks drawn from the battery or input power source and lessens switching noise in the controller. The impedance of the input capacitor at the switching frequency should be less than that of the

input source so that high-frequency switching currents do not pass through the input source.

The output capacitor is required to keep the output voltage ripple small and to ensure stability of the regulation control loop. The output capacitor must have low impedance at the switching frequency. Tantalum and ceramic capacitors are good choices. Tantalum capacitors typically have high capacitance and medium-to-low equivalent series resistance (ESR) so that ESR dominates the impedance at the switching frequency. In turn, the output ripple is approximately:

$$V_{RIPPLE} \approx I_L(PEAK) ESR$$

where $I_L(PEAK)$ is the peak inductor current.

Ceramic capacitors typically have lower ESR than tantalum capacitors, but with relatively small capacitance that dominates the impedance at the switching frequency. In turn, the output ripple is approximately:

$$V_{RIPPLE} \approx I_L(PEAK) Z_C$$

where $I_L(PEAK)$ is the peak inductor current, and $Z_C \approx 1 / (2\pi f_{OSC} C_{OUT})$.

See the *Compensation Design* section for a discussion of the influence of output capacitance and ESR on regulation control loop stability.

The capacitor voltage rating must exceed the maximum applied capacitor voltage. For most tantalum capacitors, manufacturers suggest derating the capacitor by applying no more than 70% of the rated voltage to the capacitor. Ceramic capacitors are typically used up to the voltage rating of the capacitor. Consult the manufacturer's specifications for proper capacitor derating.

Bypass Capacitors

If the MAX1801 is placed far from the MAX1800 or MAX1802 master IC, noise from switching circuits can affect the MAX1801. Should this be the case, bypass REF and IN with 0.1 μ F or greater ceramic capacitors. If noise is not a problem or if the MAX1801 is placed close to the master IC, then no extra bypassing is required.

MOSFET Selection

The MAX1801 controller drives an external logic-level N-channel MOSFET as the circuit switch element. The key selection parameters are as follows:

- On-resistance ($R_{DS(ON)}$)
- Maximum drain-to-source voltage ($V_{DS(MAX)}$)
- Minimum threshold voltage ($V_{TH(MIN)}$)
- Total gate charge (Q_g)
- Reverse transfer capacitance (C_{RSS})

Digital Camera Step-Up Slave DC-DC Controller

Since the external gate drive (DL) swings between IN and GND, use a MOSFET whose on-resistance is specified at or below VIN. The gate charge, Qg, includes all capacitance associated with gate charging and helps to predict the transition time required to drive the MOSFET between on and off states. The power dissipated in the MOSFET is due to on-resistance and transition losses. The on-resistance loss is:

$$P_1 \approx D I_L^2 R_{DS(ON)}$$

where D is the duty cycle, IL is the average inductor current, and RDS(ON) is the on-resistance of the MOSFET. The transition loss is approximately:

$$P_2 \approx \frac{V_{OUT} I_L f_{OSC} t_T}{3}$$

where VOUT is the output voltage, IL is the average inductor current, fOSC is the converter switching frequency, and tT is the transition time. The transition time is approximately Qg / IG, where Qg is the total gate charge and IG is the gate drive current (typically 0.5A).

The total power dissipation in the MOSFET is:

$$P_{MOSFET} = P_1 + P_2$$

Diode Selection

For low-output-voltage applications, use a Schottky diode to rectify the output voltage because of the diode's low forward voltage and fast recovery time. Schottky diodes exhibit significant leakage current at high reverse voltages and high temperatures. Thus, for high-voltage, high-temperature applications, use ultra-fast junction rectifiers.

Compensation Design

MAX1801 converters use voltage mode to regulate their output voltages. The following explains how to compensate the control system for optimal performance. The compensation differs depending on whether the inductor current is continuous or discontinuous.

Discontinuous Inductor Current

For discontinuous inductor current, the PWM converter has a single pole. The pole frequency and DC gain of the PWM controller are dependent on the operating duty cycle, which is:

$$D = (2 L f_{OSC} / R_E)^{1/2}$$

where RE is the equivalent load resistance, or:

$$R_E = V_{IN}^2 R_{LOAD} / (V_{OUT} (V_{OUT} - V_{IN}))$$

The frequency of the single pole due to the PWM converter is:

$$P_O = (2 V_{OUT} - V_{IN}) / (2 \pi (V_{OUT} - V_{IN}) R_{LOAD} C_{OUT})$$

And the DC gain of the PWM controller is:

$$A_{VO} = 2 V_{OUT} (V_{OUT} - V_{IN}) R_{LOAD} / ((2 V_{OUT} - V_{IN}) D)$$

Note that the pole frequency decreases and the DC gain increases proportionally as the load resistance (RLOAD) is increased. Since the crossover frequency is the product of the pole frequency and the DC gain, it remains independent of the load.

The gain through the voltage-divider is:

$$A_{VDV} = V_{REF} / V_{OUT}$$

And the DC gain of the error amplifier is AVEA = 2000V/V. Thus, the DC loop gain is:

$$A_{VDC} = A_{VDV} A_{VEA} A_{VO}$$

The compensation resistor-capacitor pair at COMP cause a pole and zero at frequencies (in Hz):

$$P_C = G_{EA} / (4000 \pi C_C) = 1 / (4 \times 10^7 \pi C_C)$$

$$Z_C = 1 / (2 \pi R_C C_C)$$

And the ESR of the output filter capacitor causes a zero in the loop response at the frequency (in Hz):

$$Z_O = 1 / (2 \pi C_{OUT} ESR)$$

The DC gain and the poles and zeros are shown in the Bode plot of Figure 4.

To achieve a stable circuit with the Bode plot of Figure 4, perform the following procedure:

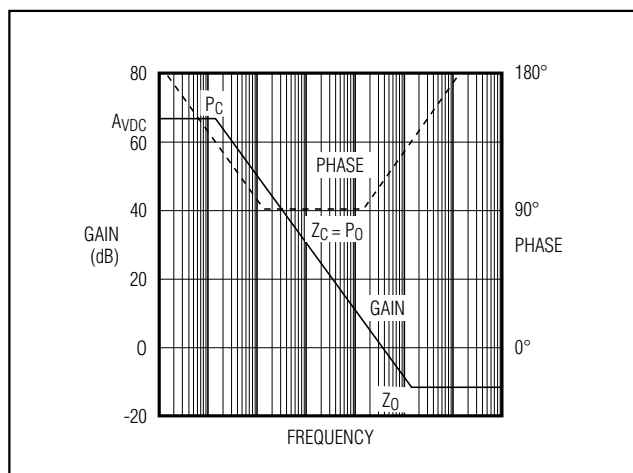

Figure 4. MAX1801 Discontinuous-Current, Voltage-Mode, Step-Up Converter Bode Plot

Digital Camera Step-Up Slave DC-DC Controller

- 1) Choose the compensation resistor R_C that is equivalent to the inverse of the transconductance of the error amplifier, $1/R_C = G_{EA} = 100\mu S$, or $R_C = 10k\Omega$. This sets the high-frequency voltage gain of the error amplifier to 0dB.

- 2) Determine the maximum output pole frequency:

$$P_{O(MAX)} = \frac{2V_{OUT} - V_{IN}}{2\pi(V_{OUT} - V_{IN}) R_{LOAD(MIN)} C_{OUT}}$$

where:

$$R_{LOAD(MIN)} = V_{OUT} / I_{OUT(MAX)}$$

- 3) Place the compensation zero at the same frequency as the maximum output pole frequency (in Hz):

$$Z_C = \frac{1}{2\pi R_C C_C} = \frac{2V_{OUT} - V_{IN}}{2\pi(V_{OUT} - V_{IN}) R_{LOAD(MIN)} C_{OUT}}$$

Solving for C_C :

$$C_C = C_{OUT} V_{OUT} \left[\frac{V_{OUT} - V_{IN}}{R_C I_{OUT(MAX)} (2V_{OUT} - V_{IN})} \right]$$

Use values of C_C less than 10nF. If the above calculation determines that the capacitor should be greater than 10nF, use $C_C = 10nF$, skip step 4, and proceed to step 5.

- 4) Determine the crossover frequency (in Hz):

$$f_C = V_{REF} / (\pi D C_{OUT})$$

and to maintain at least a 10dB gain margin, make sure that the crossover frequency is less than or equal to 1/3 of the ESR zero frequency, or:

$$3f_C \leq Z_O$$

or:

$$ESR \leq D / 6 V_{REF}$$

If this is not the case, go to step 5 to reduce the error amplifier high-frequency gain to decrease the crossover frequency.

- 5) The high-frequency gain may be reduced, thus reducing the crossover frequency, as long as the zero due to the compensation network remains at or below the crossover frequency. In this case:

$$ESR \leq D / (G_{EA} R_C 6 V_{REF})$$

and:

$$f_C = (G_{EA} R_C) 2 V_{REF} / (2\pi D C_{OUT}) \geq 1 / (2\pi R_C C_C)$$

Choose C_{OUT} , R_C , and C_C to simultaneously satisfy both equations.

Continuous Inductor Current

For continuous inductor current, there are two conditions that change, requiring different compensation. The response of the control loop includes a right-half-plane zero and a complex pole pair due to the inductor and output capacitor. For stable operation, the controller loop gain must drop below unity (0dB) at a much lower frequency than the right-half-plane zero frequency. The zero arising from the ESR of the output capacitor is typically used to compensate the control circuit by increasing the phase near the crossover frequency, increasing the phase margin. If a low-value, low-ESR output capacitor (such as a ceramic capacitor) is used, the ESR-related zero occurs at too high a frequency and does not increase the phase margin. In this case, use a lower value inductor so that it operates with discontinuous current (see the *Discontinuous Inductor Current* section).

For continuous inductor current, the gain of the voltage divider is $A_{VDV} = V_{REF} / V_{OUT}$, and the DC gain of the error amplifier is $A_{VEA} = 2000$. The gain through the PWM controller in continuous current is:

$$A_{VO} = (1 / V_{REF}) (V_{OUT}^2 / V_{IN})$$

Thus, the total DC loop gain is:

$$A_{VDC} = 2000 V_{OUT} / V_{IN}$$

The complex pole pair due to the inductor and output capacitor occurs at the frequency (in Hz):

$$P_O = (V_{OUT} / V_{IN}) / (2\pi (L \times C_{OUT})^{1/2})$$

The pole and zero due to the compensation network at COMP occur at the frequencies (in Hz):

$$P_C = G_{EA} / (4000 \pi C_C) = 1 / (4 \times 10^7 \pi C_C)$$

$$Z_C = 1 / (2\pi R_C C_C)$$

The frequency (in Hz) of the zero due to the ESR of the output capacitor is:

$$Z_O = 1 / (2\pi C_{OUT} ESR)$$

And the right-half-plane zero frequency (in Hz) is:

$$Z_{RHP} = \frac{(1-D)^2 R_{LOAD}}{2\pi L}$$

The Bode plot of the loop gain of this control circuit is shown in Figure 5.

Digital Camera Step-Up Slave DC-DC Controller

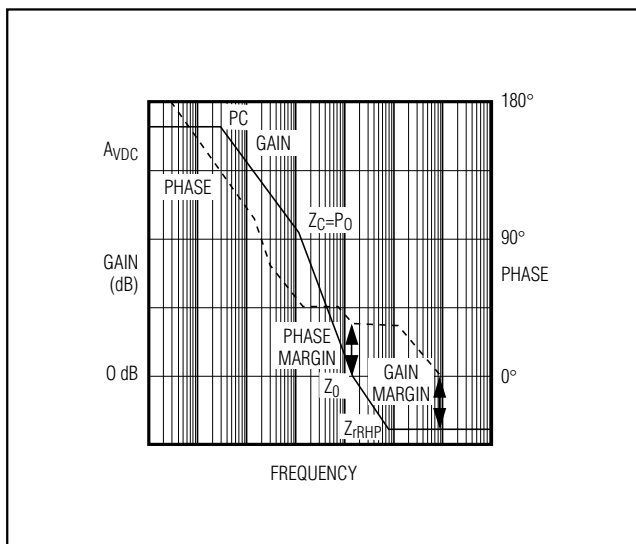

Figure 5. MAX1801 Continuous-Current, Voltage-Mode, Step-Up Converter Bode Plot

To configure the compensation network for a stable control loop, set the crossover frequency at that of the zero due to the output capacitor ESR. Use the following procedure:

- 1) Determine the frequency of the right-half-plane zero:

$$Z_{RHP} = \frac{(1-D)^2 R_{LOAD}}{2\pi L}$$

- 2) Find the DC loop gain:

$$A_{VDC} = 2000 V_{OUT} / V_{IN}$$

- 3) Determine the frequency of the complex pole pair due to the inductor and output capacitor:

$$f_0 = (V_{OUT} / V_{IN}) / (2\pi (L C_{OUT})^{1/2})$$

- 4) Since response is 2nd order (-40dB per decade) between the complex pole pair and the ESR zero, determine the desired amplitude at the complex pole pair to force the crossover frequency equal to the ESR zero frequency. Thus:

$$A(P_0) = (Z_0 / P_0)^2 = L V_{IN}^2 / (C_{OUT} ESR^2 V_{OUT}^2)$$

- 5) Determine the desired compensation pole. Since the response between the compensation pole and the complex pole pair is 1st order (-20dB per decade), the ratio of the frequencies is equal to the ratio of the amplitudes at those frequencies. Thus:

$$(P_0 / P_C) = (A_{DC} / A(P_0))$$

Solving this equation for C_C :

$$C_C = V_{OUT} (C_{OUT})^{3/2} ESR^2 / (20M\Omega V_{IN} (L)^{1/2})$$

- 6) Determine that the compensation resistor, R_C for the compensation zero frequency, is equal to the complex pole-pair frequency:

$$Z_C = P_0$$

solving for R_C :

$$R_C = (V_{IN} / V_{OUT}) ((L C_{OUT})^{1/2} / C_C)$$

Applications Information

Using the MAX1801 with the MAX1800 Step-Up Master DC-DC Converter

The MAX1801 does not generate its own reference or oscillator. Instead it uses the reference and the oscillator from a master DC-DC converter such as the MAX1800 step-up master converter. The MAX1800 has circuitry to generate a 1.25V reference and a 100kHz to 1MHz oscillator signal. The MAX1800 operates from a 1.5V to 5.5V input voltage, which makes it suitable for applications with 2- or 3-cell alkaline, NiCd, or NiMH batteries, or 1-cell lithium primary or lithium-ion (Li+) batteries. Apart from the reference and the oscillator, the MAX1801 has a single-internal-switch synchronous-rectified step-up DC-DC converter, three auxiliary step-up DC-DC converter controllers, and a linear regulator controller. For more details, refer to the MAX1800 data sheet

Using the MAX1801 with the MAX1802 Step-Down Master DC-DC Converter

The MAX1801 does not generate its own reference or oscillator. Instead, it uses the reference and the oscillator from a master DC-DC converter such as the MAX1802 step-down master DC-DC converter. The MAX1802 has circuitry to generate a 1.25V reference and a 100kHz to 1MHz oscillator signal. The MAX1802 operates from a 2.7V to 11V input voltage, making it suitable for 4-series alkaline, NiCd, or NiMH cells, or 2-series lithium primary or (Li+) batteries. The MAX1802 has a synchronous-rectified step-down DC-DC converter controller, an internal-switch synchronous-rectified step-down DC-DC converter, and three auxiliary step-up DC-DC converter controllers. For more details, refer to the MAX1802 data sheet.

Digital Camera Step-Up Slave DC-DC Controller

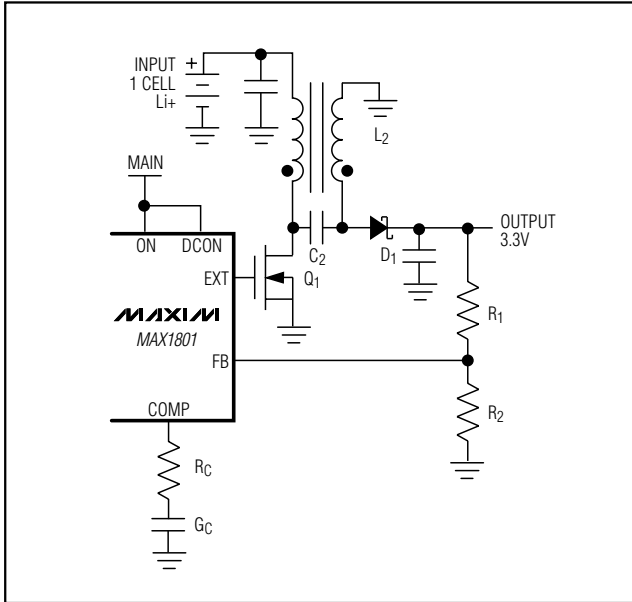

Figure 6. MAX1801 Auxiliary Controller, SEPIC Configuration

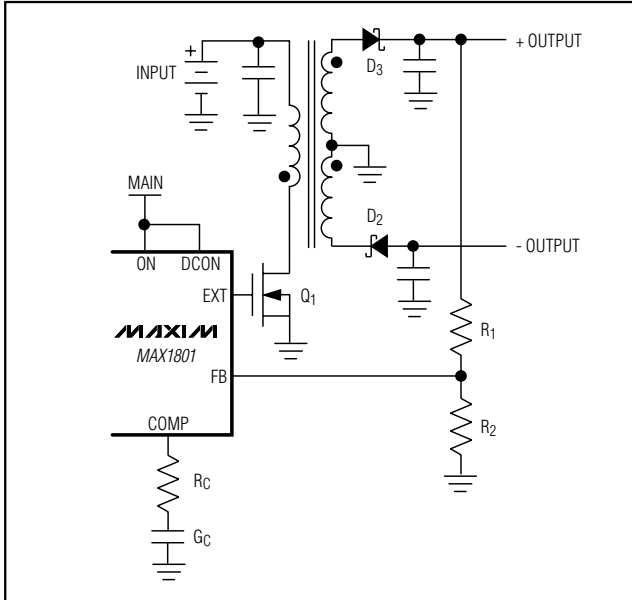

Figure 7. MAX1801 Auxiliary Controller, Flyback Configuration

Using the MAX1801 Controller in SEPIC Configuration

In cases where the battery voltage is above or below the required output voltage, neither a step-up nor a

step-down converter is suitable; use a step-up/step-down converter instead. One type of step-up/step-down converter is the SEPIC shown in Figure 6. Inductors L1 and L2 can be separate inductors or can be wound on a single core and coupled as with a transformer. Typically, using a coupled inductor improves efficiency because some power is transferred through the coupling so that less power passes through the coupling capacitor, C2. Likewise, C2 should be a low-ESR-type capacitor to improve efficiency. The coupling capacitor ripple current rating must be greater than the larger of the input and output currents. The MOSFET (Q1) drain-source voltage rating and the rectifier (D1) reverse voltage rating must exceed the sum of the input and output voltages. Other types of step-up/step-down circuits are a flyback converter and a step-up converter followed by a linear regulator.

Using the MAX1801 Controller for a Multi-Output Flyback Circuit

Some applications require multiple voltages from a single converter that features a flyback transformer. Figure 7 shows a MAX1801 auxiliary controller in a two-output flyback configuration. The controller drives an external MOSFET that switches the transformer primary, and the two secondaries generate the outputs. Only a single positive output voltage can be regulated using the feedback resistive voltage-divider, so the other voltages are set by the turns ratio of the transformer secondaries. The regulation of the other secondary voltages degrades due to transformer leakage inductance and winding resistance. Voltage regulation is best when the load current is limited to a small range. Consult the transformer manufacturer for the proper design for a given application.

Using a Charge Pump to Make Negative Output Voltages

Negative output voltages can be produced without a transformer using a charge-pump circuit with an auxiliary controller, as shown in Figure 8. When MOSFET Q1 turns off, the voltage at its drain rises to supply current to V_{OUT+} . At the same time, C1 charges to the voltage at V_{OUT+} through D1. When the MOSFET turns on, C1 discharges through D3, thereby charging C3 to V_{OUT-} minus the drop across D3, to create roughly the same voltage as V_{OUT+} at V_{OUT-} but with inverted polarity. If different magnitudes are required for the positive and negative voltages, a linear regulator can be used at one of the outputs to achieve the desired voltages, while the MAX1801 regulates the higher magnitude voltage.

Digital Camera Step-Up Slave DC-DC Controller

MAX1801

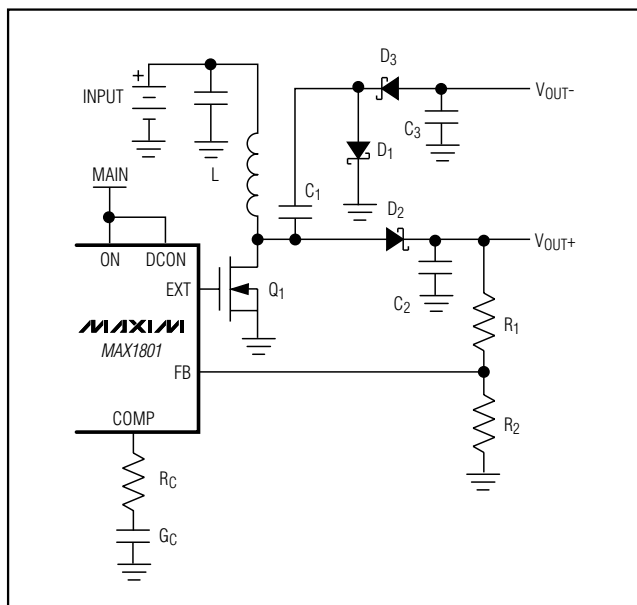

Figure 8. Auxiliary Controller, Charge-Pump Configuration

Designing a PC Board

A good PC board layout is important to achieve optimal performance from the MAX1801. Poor design can cause excessive conducted and/or radiated noise, both of which can cause instability and/or regulation errors.

Conductors carrying discontinuous currents should be kept as short as possible, and conductors carrying high currents should be made as wide as possible. A

separate low-noise ground plane containing the reference and signal grounds should connect only to the power-ground plane at one point to minimize the effects of power-ground currents.

Keep the voltage feedback network very close to the IC, preferably within 0.2in (5mm) of the FB pin. Nodes with high dv/dt (switching nodes) should be kept as small as possible and should be kept away from high-impedance nodes such as FB.

Circuit-board layouts that are susceptible to electrical noise can require a lowpass RC filter at OSC and bypassing at REF and IN. If an RC filter is used at OSC, the pole frequency should be at least 20 times larger than the oscillator frequency to prevent distortion of the OSC signal. To ensure minimal loading of the master oscillator, which would cause an oscillator frequency shift, choose a filter capacitor smaller than $C_{OSC}/(100N)$, where C_{OSC} is the timing capacitor for the master oscillator and N is the number of MAX1801 slaves connected to the master. Then choose $R_{FILTER} = 1/(40\pi f_{OSC} C_{FILTER})$.

If bypass capacitors are required on IN and REF, use 0.1 μ F ceramic capacitors because of their low impedance at high frequencies. The bypass and filter components should be placed within 5mm (0.2in) of the MAX1801 pins.

Refer to the MAX1800 evaluation kit (EV kit) or MAX1802 EV kit data sheets for full PC board examples.

Pin Configuration

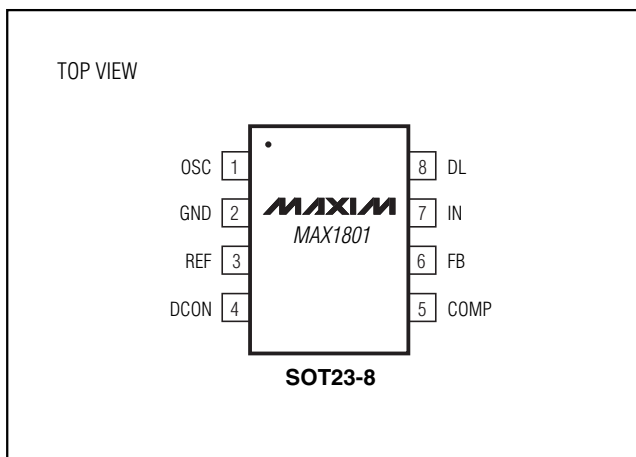

Chip Information

TRANSISTOR COUNT: 1130

Digital Camera Step-Up Slave DC-DC Controller

Package Information

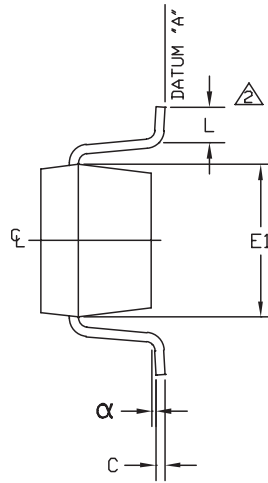
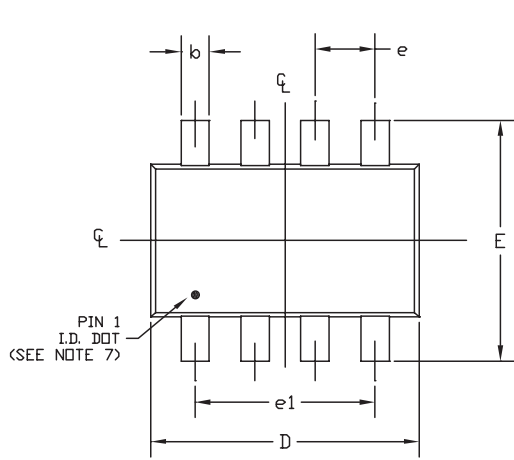

SYMBOL	MIN	MAX
A	0.90	1.45
A1	0.00	0.15
A2	0.90	1.30
b	0.28	0.45
C	0.09	0.20
D	2.80	3.00
E	2.60	3.00
E1	1.50	1.75
L	0.10	0.60
e	0.65 ref	
e1	1.95 ref	
α	0°	10°

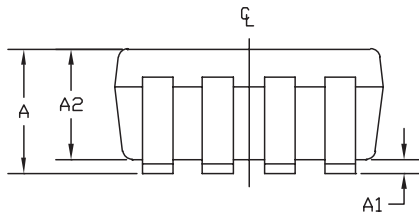

- NOTE:
1. ALL DIMENSIONS ARE IN MILLIMETERS.
 2. FOOT LENGTH MEASURED REFERENCE TO FLAT FOOT SURFACE PARALLEL TO DATUM 'A'.
 3. PACKAGE OUTLINE EXCLUSIVE OF MOLD FLASH & METAL BURR.
 4. PACKAGE OUTLINE INCLUSIVE OF SOLDER PLATING.
 5. EIAJ REF. NUMBER SC-74 (6 LEAD VERSION)
 6. COPLANARITY 4 MILS. MAX.
 7. PIN 1 I.D. DOT IS 0.3 MM ϕ MIN. LOCATED ABOVE PIN 1.

MAXIM

PROPRIETARY INFORMATION

TITLE:
PACKAGE OUTLINE, SOT 23, 8L

APPROVAL	DOCUMENT CONTROL NO. 21-0078	REV B	1/1
----------	---------------------------------	----------	-----

SOT23, 8LEPS

Maxim cannot assume responsibility for use of any circuitry other than circuitry entirely embodied in a Maxim product. No circuit patent licenses are implied. Maxim reserves the right to change the circuitry and specifications without notice at any time.

16 _____ **Maxim Integrated Products, 120 San Gabriel Drive, Sunnyvale, CA 94086 408-737-7600**